

DFL 150 A

CENTRIFUGA A SCARICO AUTOMATICO



Gruppo pulizia fango



Scambiatore acqua chiarificata

Informazioni tecniche

	DFL 150 A
Portata	150 l/min
Qualità	5 μ m
Dimensioni	LxLxH (2200x2000x2300) mm
Peso	950 Kg
Area	5 m ²
Tensione	400 V 50 Hz
Potenza	9 Kw



	DFL 150 A
P1	Pompa carico 230V 50Hz 1,5 Kw
P2	Pompa rilancio 230V 50Hz 1,5 Kw
E1	3P+N+E 400V 50Hz Potenza installata 9 Kw

Vista di fronte

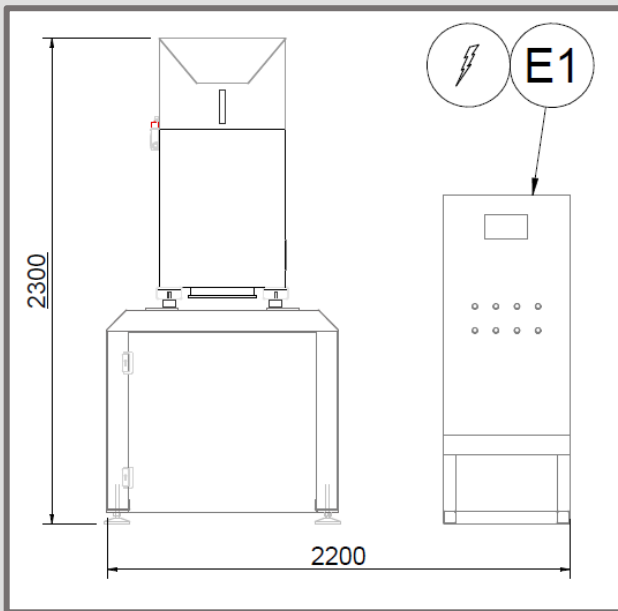

Vista dall'alto

