

# DFL 150-250 A Duplex

## AUTOMATIC DISCHARGE CENTRIFUGE



Mud cleaning unit



Clarified water exchanger

### Technical information

	DFL 150 A	DFL 250 A
Flow	150 l/min	250 l/min
Quality	5 $\mu\text{m}$	5 $\mu\text{m}$
Dimensions	LxLxH (2200x2000x2300) mm	LxLxH (2200x2000x2500) mm
Weight	950 Kg	1150 Kg
Area	5 m <sup>2</sup>	5 m <sup>2</sup>
Tension	400 V 50 Hz	400 V 50 Hz
Power	10,5 Kw	12,5 Kw



Plant information

	DFL 150 A	DFL 250 A
P1	Feeding pump 230V 50Hz 1,5 Kw	Feeding pump 230V 50Hz 1,5 Kw
P2	Feeding pump 230V 50Hz 1,5 Kw	Feeding pump 230V 50Hz 1,5 Kw
P3	Booster pump 230V 50Hz 1,5 Kw	Booster pump 230V 50Hz 1,5 Kw
E1	3P+N+E 400V 50Hz 10,5 Kw	3P+N+E 400V 50Hz 12,5 Kw

Front view

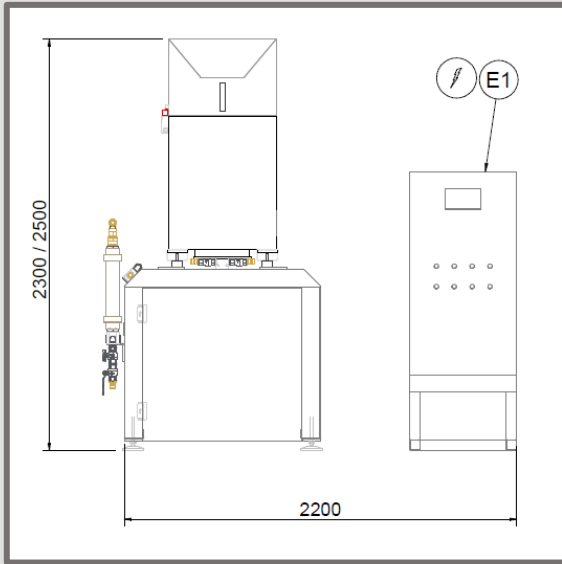

Top view

