

DFL 150-250 A Duplex

CENTRIFUGA A SCARICO AUTOMATICO



Gruppo pulizia fango



Scambiatore acqua chiarificata

Informazioni tecniche

	DFL 150 A	DFL 250 A
Portata	150 l/min	250 l/min
Qualità	5 μ m	5 μ m
Dimensioni	LxLxH (2200x2000x2300) mm	LxLxH (2200x2000x2500) mm
Peso	950 Kg	1150 Kg
Area	5 m ²	5 m ²
Tensione	400 V 50 Hz	400 V 50 Hz
Potenza	10,5 Kw	12,5 Kw

	DFL 150 A	DFL 250 A
P1	Pompa carico 230V 50Hz 1,5 Kw	Pompa carico 230V 50Hz 1,5 Kw
P2	Pompa carico 230V 50Hz 1,5 Kw	Pompa carico 230V 50Hz 1,5 Kw
P3	Pompa rilancio 230V 50Hz 1,5 Kw	Pompa rilancio 230V 50Hz 1,5 Kw
E1	3P+N+E 400V 50Hz 10,5 Kw	3P+N+E 400V 50Hz 12,5 Kw

Vista di fronte

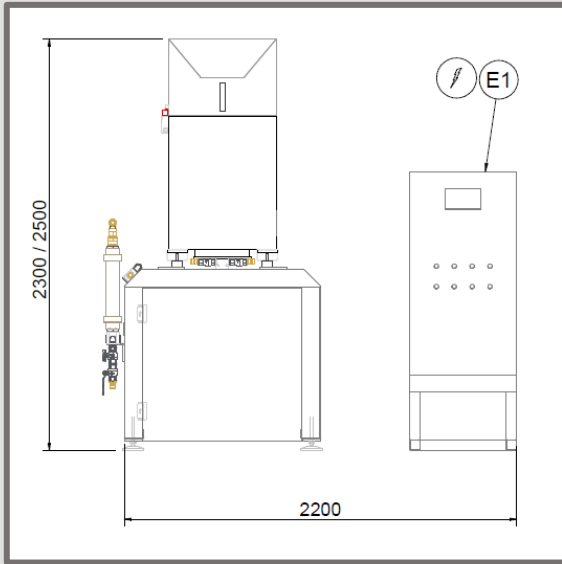

Vista dall'alto

